

# TM 9-1240-297-35

DEPARTMENT OF THE ARMY TECHNICAL MANUAL

## FIELD AND DEPOT MAINTENANCE MANUAL

### TELESCOPE MOUNT M110

This publication is a courtesy quick copy from the UNITED STATES ARMY PUBLICATIONS CENTER, ST. LOUIS, MISSOURI, to meet your needs while we are replenishing our regular stock.

---

*HEADQUARTERS, DEPARTMENT OF THE ARMY  
AUGUST 1961*



Technical Manual }  
 No. 9-1240-297-35 }

HEADQUARTERS,  
 DEPARTMENT OF THE ARMY  
 WASHINGTON 25, D. C., 10 August 1961

**TELESCOPE MOUNT M110**

---

		Paragraph	Page
CHAPTER 1.	INTRODUCTION		2
Section I.	General . . . . .	1-3	2-3
	II. Description and data . . . . .	4-6	3
CHAPTER 2.	TOOLS AND EQUIPMENT	7-12	4, 5
CHAPTER 3.	INSPECTION		9
Section I.	General . . . . .	13-16	9-10
	II. Inspection of telescope mount M110 in the hands of troops . . . . .	17-19	10
	III. Ordnance shop inspection . . . . .	20-21	10
	IV. Preembarkation inspection . . . . .	22-23	11
CHAPTER 4.	TROUBLESHOOTING	24-25	12
CHAPTER 5.	REPAIR AND OVERHAUL		13
Section I.	General . . . . .	26-27	13
	II. Disassembly . . . . .	28-33	13-14
	III. Assembly . . . . .	34-39	17
	IV. Test and adjustment . . . . .	40-43	18-20
CHAPTER 6.	FINAL INSPECTION.	44-46	24
CHAPTER 7.	PROCESSING AND PACKAGING . . . . .	47	25
APPENDIX	REFERENCES . . . . .		26
INDEX . . . . .			29

# CHAPTER 1

## INTRODUCTION

---

### Section I. GENERAL

#### 1. Scope

a. This manual contains instructions for the information of personnel responsible for field and depot maintenance of telescope mount M110, which is beyond the scope of the tools, equipment, or supplies normally available to using organizations.

b. This manual contains a description of telescope mount M110. It also specifies troubleshooting procedures, disassembly, repair and overhaul, and assembly of telescope mount M110 peculiar to field and depot maintenance. The instructions in this manual are intended for maintenance specialists who have been thoroughly trained in maintenance practices.

c. The maintenance functions contained in this manual describes the concept of IROAN (Inspect and Repair Only as Necessary). This technique is applicable to the maintenance of telescope mount M110, at all echelons of maintenance. It does not change or lower the required quality of maintenance or prescribed serviceability standards.

d. The appendix contains a list of current references, including supply and technical manuals, forms, and other available publications applicable to telescope mount M110. The maintenance allocation chart is included in TM 9-1015-223-12. TM 9-1240-297-35P lists repair parts and special tools authorized to field and depot personnel.

e. Operation, lubrication, and all maintenance operations allocated to using organizations in performing maintenance work within their scope for the telescope mount M110 are contained in TM 9-1015-223-12.

f. *This* first edition is being published in advance of complete technical review. Any errors or omissions will be forwarded

on DA Form 2028 direct to the Commanding Officer, Raritan Arsenal, Metuchen, New Jersey, ATTN: ORDJR-OPRA.

#### 2. Maintenance Allocation and Parts

a. Field maintenance responsibilities prescribed in this manual will apply as reflected in the maintenance allocation chart in TM 9-1015-223-12 and as reflected by the allocation of repair parts and tools listed in TM 9-1240-297-35P.

b. Depot maintenance responsibilities will provide for complete overhaul of telescope mount M110 as reflected by the IROAN concept for the purpose of repairing or overhauling an unserviceable item.

c. Depot maintenance parts are listed in TM 9-1240-297-35P, which is the authority for requisitioning replacements. Parts not listed therein but required by depot shops may be requisitioned and will be supplied, if available, when the need is substantiated. Requisitions for parts not listed in TM 9-1240-297-35P will contain a complete justification of requirements. Requisitions for assemblies will be held to a minimum. Whenever possible, overhaul of assemblies will be accomplished. When feasible, local fabrication maybe required for those parts unable to be supplied.

#### 3. Forms, Records, and Reports

a. General. Responsibility for the proper execution of forms, records, and reports rests upon the commanding officers of all units maintaining this equipment. However, the value of accurate records must be fully appreciated by all persons responsible for their compilation, maintenance, and use. Records, reports, and authorized forms are normally utilized to indicate the type, quantity, and condition of materiel to be inspected, to be repaired, or to be used in repair. Properly executed

forms convey authorization and serve as records of work performed. The forms, records, and reports establish the work required, the progress of the work and the status of the materiel upon completion of its repair.

*b. Authorized Forms.* The forms generally applicable to units maintaining this materiel are listed in the appendix. For instructions in the use of these forms, refer to FM 9-3 and FM 9-4. For a listing of all forms, refer to DA Pam 310-2.

*c. Field Reports of Accidents.* The re-

ports necessary to comply with the requirements of the Army Safety program are prescribed in detail in AR 385-40. These reports are required whenever accidents involving injury to personnel or damage to materiel occur.

*d. Reports of Unsatisfactory Equipment or Materials.* Any deficiencies detected in the equipment covered herein, which occur under the circumstances indicated in AR 700-38, should be immediately reported in accordance with the applicable instructions in cited regulation.

## Section II. DESCRIPTION AND DATA

### 4. General

This section provides an overall description of the major item and includes a reference to the materiel with which it is used. It also describes the main components and how they tie into the complete telescope mount M110.

### 5. Description

*a.* Telescope mount M110 (fig. 1) holds telescope M103 to the 90-mm rifle M67. It is designed so that the telescope can be inserted and seated rapidly and with assured replacement accuracy.

*b.* The parts and mechanism of telescope mount M110 are contained in a steel housing. A retaining ring which threads onto the outside of the telescope mount housing holds the mount to the front bracket assembly of the weapon. Four nylon pins in the ring grip the threads on the housing and prevent the ring from loosening.

*c.* A cylindrically-shaped flange on a gimbal tube fits snugly into the bore of telescope mount M110. The gimbal tube has three segments of a helical-pitch left-handed thread machined at one end of the internal bore, to engage mating threads on

the telescope M103. A conically-shaped shoulder at the other end of the bore of the tube matches the shoulder on the telescope. Telescope mount M110 also features a device which enables boresight adjustments.

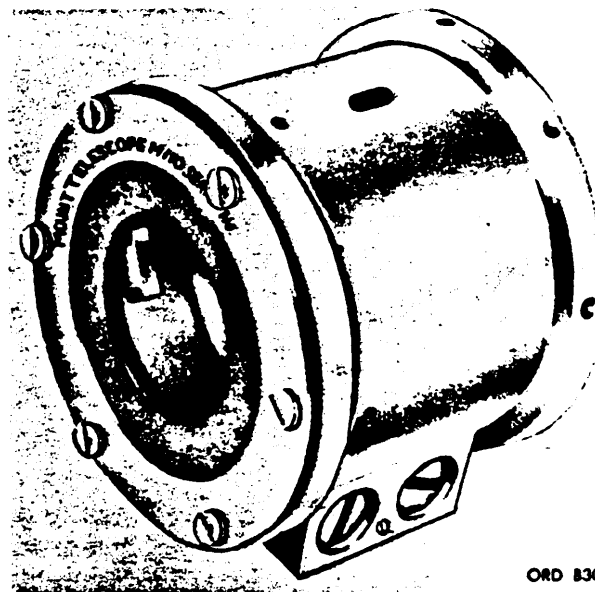

ORD 83035

Figure 1. Telescope mount M110.

### 6. Data

Length	-----	-1-11/16 in.
Diameter	-----	-2-3/16 in.
Weight	-----	-15 oz

## CHAPTER 2

### TOOLS AND EQUIPMENT

#### 7. General

Tools and equipment over and above those available to the using organization are supplied to field and depot maintenance units for repair, overhaul, and adjustments of telescope mount M110.

#### 8. Common Tools and Equipment

Standard and commonly used tools and equipment having general application to

this materiel are authorized for issue by tables of allowances and tables of organization and equipment.

#### 9. Special Tools and Equipment

The tools and equipment specially designed for maintenance of the materiel are listed in table I for information only. For requisitioning replacements, refer to TM 9-1240-297-35P.

*Table I. Special Tools and Equipment for Depot Maintenance*

Item	Identifying number	References		Use
		Fig.	Par.	
<b>ADAPTER, test</b> .....	<b>8213875</b>	16	41, 42	<b>Hold mount to the "J" support of telescope test fixture and universal vibration tester. Support telescope mount M110 for testing. Hold mirror in place on "J" support. As a reference in checking travel of bore-sight worms. Secure test adapter to telescope test fixture. Autocollimate projector collimator. Measure amount of torque on elevation and azimuth worm. Aligning test adapter to test mount and plumbing reticle in projector collimator. To check for loose parts or dirt in the mount. Secure or remove ring assembly 8634485 on telescope mount M110. Remove or install retaining ring 7569771.</b>
<b>FIXTURE, telescope test</b> ...	<b>7573980</b>	2, 16	10,42	
<b>BRACKET, assy.</b> .....	<b>7680659</b>	2	42	
<b>COLLIMATOR, projector</b> ...	<b>7573291</b>	2	42	
<b>"J" SUPPORT</b> .....	<b>7680666</b>	2	42	
<b>MIRROR, reflecting</b> .....	<b>5181003</b>	2	42	
<b>SCREWDRIVER, torque</b> ....	<b>5120-568-4749</b>	11	37	
<b>TELESCOPE, collimating</b> ..	<b>5549108</b> <b>(18-T-540-250)</b>	5,13, 15,16	42	
<b>TESTER, universal vibration.</b>	<b>7560085</b>	3, 1 2	11,41	
<b>WRENCH, spanner pin-type.</b>	<b>8213920</b>	6	29,42	
<b>WRENCH, tubular spanner, 1-11/16 and 1-45/64.</b>	<b>5120-345-1417</b>	9	32,35	

#### 10. Telescope Test Fixture 7573980

The telescope test fixture (fig. 2) consists basically of a machined base with provisions for mounting the projector collimator 7573291, and various supports and adapters. The projector collimator is fixed rigidly on one end of the base. At the opposite end is a fixed support capable of mounting the supports and adapters. The movable telescope support, located between the fixed support and the projector collimator, may be moved in either direction on the base to accommodate telescopes of various lengths. The movable support is utilized to secure telescope mount M110 to the base of the fixture.

a. The projector collimator is an optical device similar to an ordinary straight tube telescope. It does not, however, have an erecting system as do most other telescopes. The collimator serves as a convenient indoor testing target during test and adjustments and final inspection. The target provided by the collimator is always uniform as far as intensity of illumination and clarity of image are concerned.

b. The eyepiece end of the projector collimator is machined to accommodate a lamp housing, which is provided with a clamping screw so that it may be secured to the collimator. The lamp housing is equipped with a 7-1/2-watt lamp assembly, an extension cord with a plug, and a switch for

connecting to a 110-volt outlet. The collimator contains a reticle pattern which is graduated in mils. The 1-mil square at the center is positioned so that any test, adjustment, or inspection necessitating 1/2-mil tolerance maybe accurately made. The positioning of the objective lens of the collimator is controlled by the adjustable objective scale. This scale is graduated so the objective can be accurately positioned, setting the collimator to the required distance at which parallax is removed. The scale is graduated with an infinity mark and four other marks representing 500, 200, 100, and 75 yards in range.

### 11. Universal Vibration Tester 7560085

The universal vibration tester (fig. 3), in conjunction with an appropriate adapter for telescope mount M110, is used to simulate conditions of shock and vibration normally encountered in the use of sighting and fire control materiel. Through its use, loose dirt and improperly secured components, which would effect the efficient

operation of the telescope mount, are revealed.

### 12. Fabricated Tools

Specially designed tools for inspection of telescope mount M110 during repair and overhaul are listed in table II. These tools may be fabricated for use in depot maintenance of the telescope mount, but will not be available through supply channels. Dimensional detail drawings (figs. 4 and 5) are furnished herein to enable depot shops to fabricate these tools locally.

Table II. Fabricated Tools

Item	Reference		Use
	Fig.	Par.	
ADAPTER, alignment test.	4	42	To support the collimating telescope on the telescope test fixture.
ADAPTER, with set-up block.	5	42	To establish required relationship of alignment test adapter and collimating telescope.

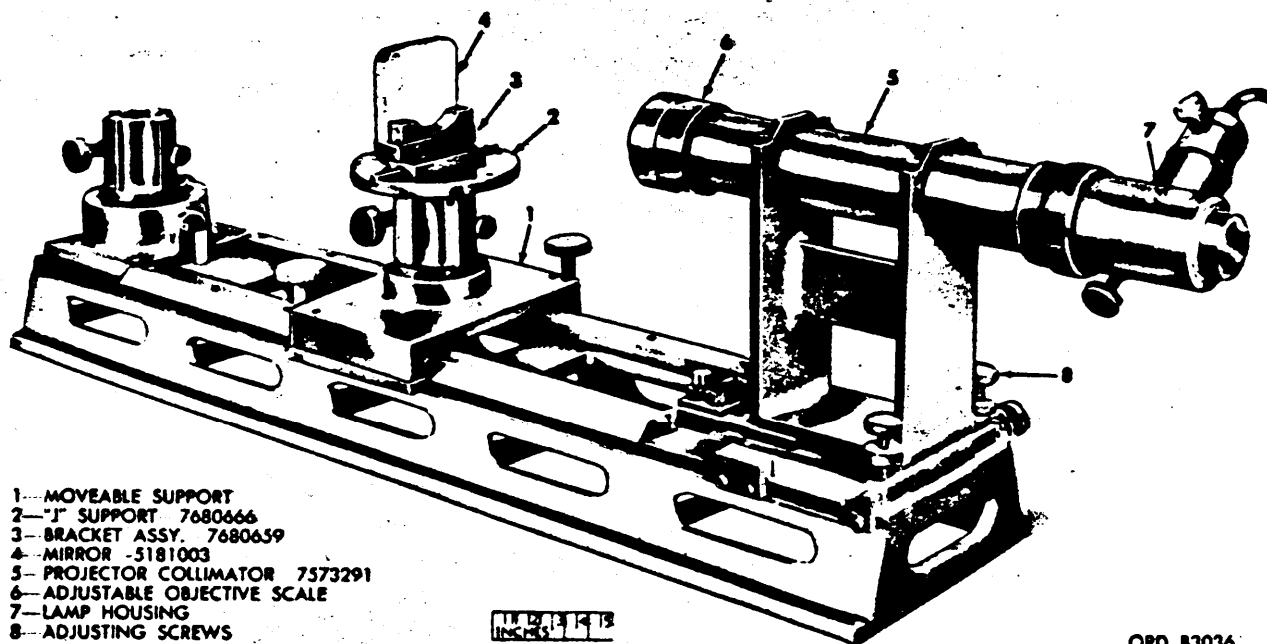

Figure 2. Telescope test fixture 7573980

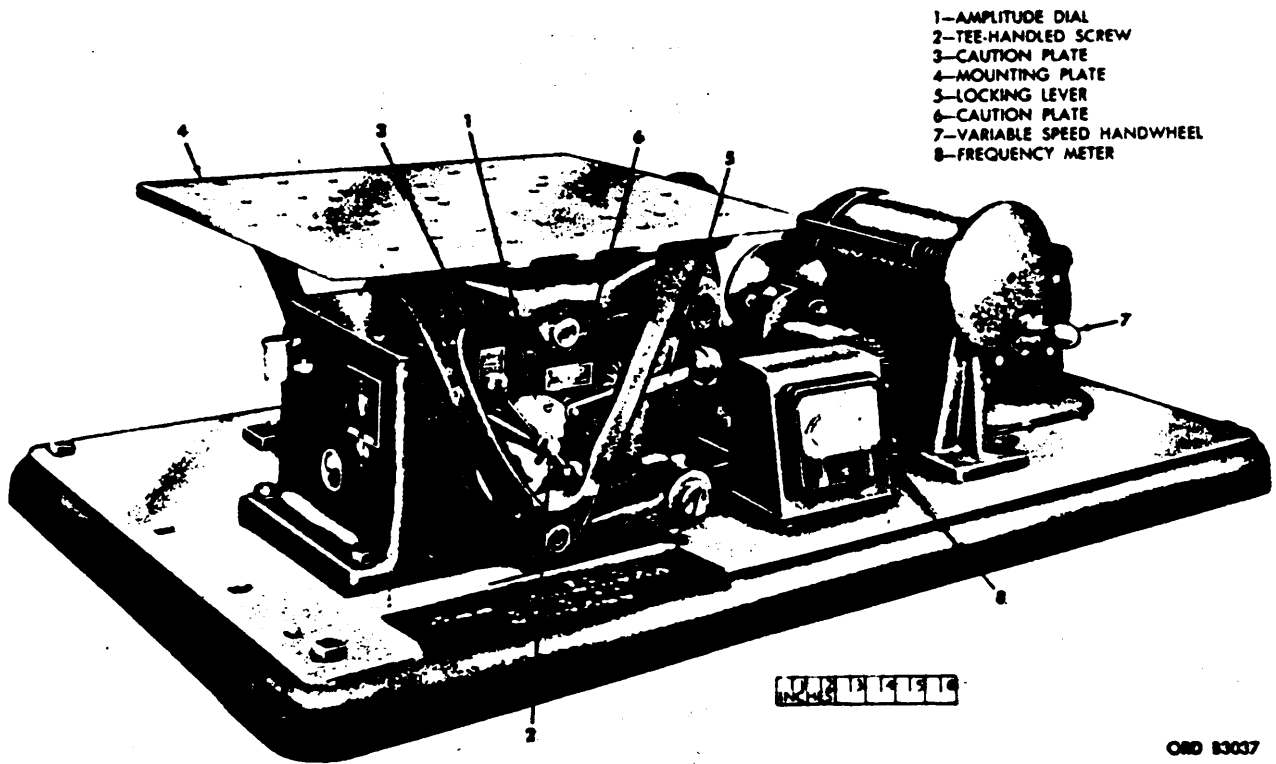
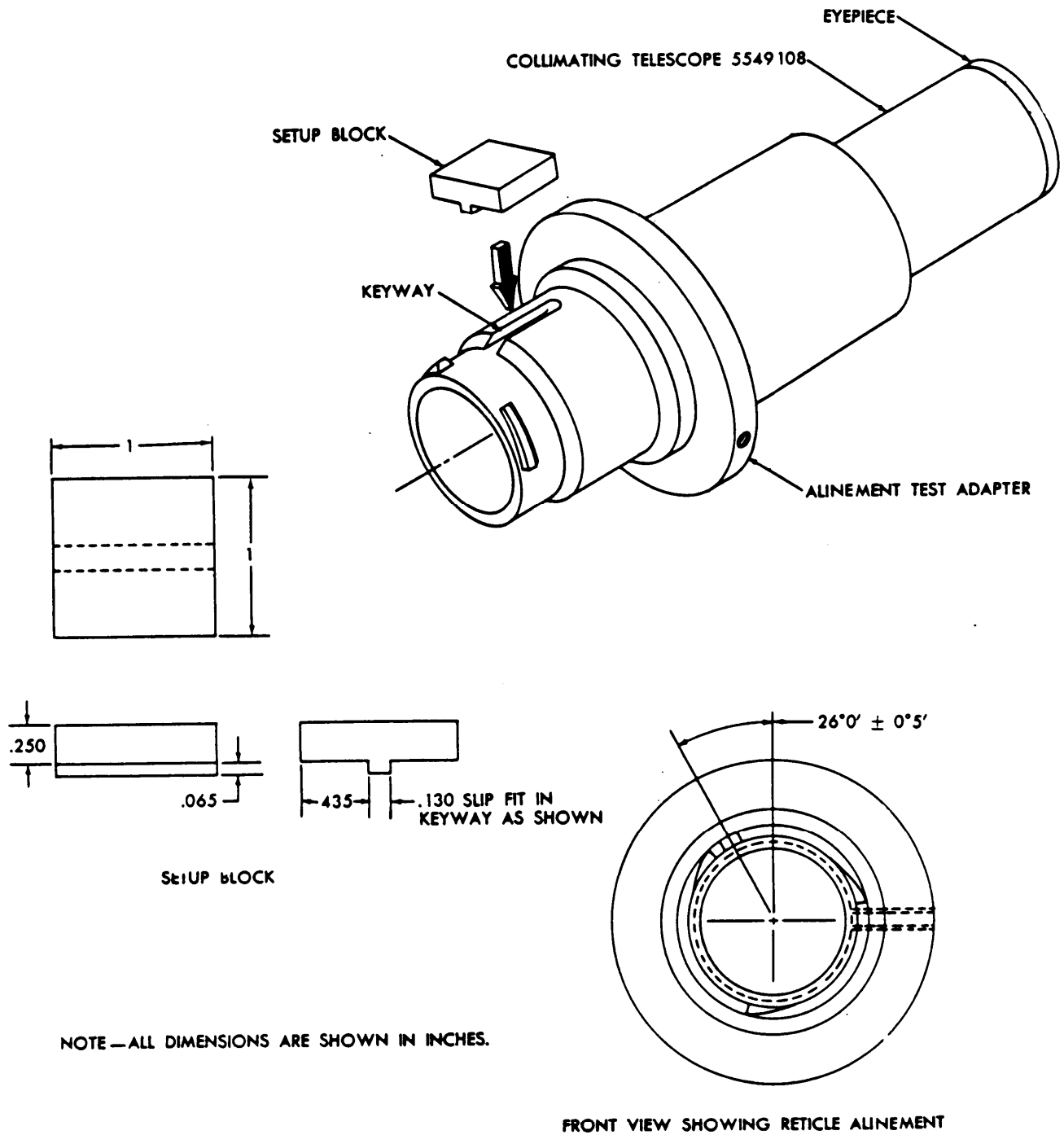

Figure 3. Universal vibration tester 7560085.







ORD B3039

Figure 5. Setting-up collimating telescope to adapter

# CHAPTER 3

## INSPECTION

---

### Section I. GENERAL

#### 13. Scope

This chapter provides specific instructions for the technical inspections by Ordnance maintenance personnel of telescope mount M110 either in the hands of troops or when received for repair in Ordnance shops. It also defines the in-process inspection of materiel during repair or overhaul and the final inspection after repair or overhaul has been completed.

#### 14. Purpose of Inspection

Inspection is primarily for the purpose of determining the condition of an item, i.e., serviceable or unserviceable; recognizing conditions which would cause failure; assuring proper allocation of maintenance policies at prescribed levels; and determining the ability of a unit to accomplish its maintenance and supply missions.

#### 15. Categories of Technical Inspections

In general, there are five categories of inspection performed by Ordnance maintenance personnel.

*a. Overall Inspection.* This is an overall inspection performed periodically on all materiel in the hands of troops. It is also performed on materiel received for repair in field or depot maintenance shops. Upon completion of an inspection for serviceability, materiel will be declared either serviceable or unserviceable. This inspection may be limited in scope, such as in inspection of materiel in the hands of troops, or detailed in scope, such as an Ordnance shop inspection. Detailed procedures are presented in section II.

*b. Preembarkation Inspection.* This inspection is performed on materiel in the hands of troops alerted for overseas duty to insure that such materiel will not become unserviceable or worn out in a re-

latively short time. It prescribes a higher percentage of remaining usable life in serviceable materiel to meet a specific need beyond minimum serviceability.

*c. In-Process Inspection.* This inspection is performed by the repair technician and/or floor inspector in the process of repairing or overhauling the materiel and its components. It insures that all parts conform to prescribed standards, that the workmanship is in accordance with approved methods and procedures, and that deficiencies disclosed by the technical inspection are found and corrected.

*d. Final Inspection.* This is an acceptance inspection performed by a final inspector after repair and overhaul has been completed, to insure that the materiel is acceptable according to established standards. Detailed instructions are contained in chapter 6.

*e. Spot-Check Inspection.* This is a periodic overall inspection performed on only a percentage of the materiel in each unit to determine the adequacy and effectiveness of organizational and field maintenance.

#### 16. Classification of Materiel

All Ordnance materiel is classified as described in a and b below.

*a. Serviceable.* Serviceable property consists of all new or used supplies which are in condition for issue for the purpose intended and all supplies which can be placed in such condition through preissue tests or inspections, in-storage deprocessing, installation of accessories, correction of minor deficiencies which have developed since the item was last classified as serviceable, application of modification work orders for which parts are available, or assembly of available components.

b. *Unserviceable*. Unserviceable property consists of all supplies which are not serviceable. The definition of unserviceable property is further broken down

into property which is unserviceable and economically repairable and property which is unserviceable and not economically repairable.

## Section II. INSPECTION OF TELESCOPE MOUNT M110 IN THE HANDS OF TROOPS

### 17. General

This section provides specific instructions for the technical inspection by Ordnance maintenance personnel of telescope mount M110 in the hands of troops. Also, this section amplifies the general instructions contained in TM 9-1100 insofar as the instructions pertain to inspection of this equipment. The inspection procedures and standards listed below apply to all telescope mounts. In general, if the telescope mount M110 is complete and performs its intended function properly, if all modification work orders classified as urgent have been completed, and if all defects as disclosed by the inspection have been corrected, the item may be considered serviceable.

### 18. Forms and Reports

Authorized forms and reports for technical inspections are prescribed in TM 9-1100. For additional authorized forms and reports for field and depot maintenance, refer to paragraph 3.

### 19. General Inspection

a. *Completeness*. Examine the instru-

ment carefully to be sure that all component parts are present. Particularly check for the presence of ring assembly, nylon pins, setscrews, and boresight screws.

b. *Appearance*. The appearance of telescope mount M110 is an indication of its general condition and will show the treatment it has received. Examine for dented surfaces, bent or broken parts, and other evidence of damage or misuse which might indicate need for repair.

c. *Engraved Lettering and Indexes*. Inspect indexes and lettering to insure that they are clearly defined and easily read.

d. *Paint and Finish*. Inspect for bare spots or damaged finish which expose bare metal surfaces and lead to corrosion. If finish is too badly damaged, a complete refinishing will be necessary.

e. *Modification Work Orders*. All modification work orders must be applied. Refer to DA Pam 310-A and the current modification work order files for modification work orders issued subsequent to this printing.

## Section III. ORDNANCE SHOP INSPECTION

### 20. General

Technical inspection performed by the Ordnance repair shop upon receipt of materiel turned-in for repair, determines the extent of the repairs required and provides the basis for requisitioning the parts, assemblies, or supplies necessary to accomplish the repairs. Often the inspection in the shop maybe the same as that performed by inspectors in the field. It may disclose additional necessary repairs not

indicated by the using organization during the field inspection. See FM 9-3 and FM 9-4 for additional information on inspections. See also final inspection portion of this manual.

### 21. Inspection

The inspections given for telescope mount M110 in the hands of troops in paragraphs 17 through 19 are pertinent also to the Ordnance shop.

## Section IV. PREEMBARKATION INSPECTION

### 22. General

Inspection for outward appearance of telescope mount M110 is of importance as well as inspection of mechanical condition. Where any doubt exists as to the utility of an assembly or of the complete telescope mount, that assembly or the complete telescope mount must be replaced by a truly serviceable item. Equipment, when inspected, must approach new equipment standards of operation and appearance and the workmanship and quality of the end product must reflect the highest standards obtainable. To assure that all items, insofar as practicable, possess original ap-

pearance, it is desired that items normally painted be repainted if the surfaces show signs or damage.

### 23. Inspection

**a. General.** Use pertinent specifications and standards as guides to insure satisfactory performance and acceptability to the telescope.

**b. Modification Work Orders.** Any modification listed in current DA Pam 310-3 or modification work order list, other than those designated as optional will be applied during repair or overhaul.

# CHAPTER 4

## TROUBLESHOOTING

### 24. Purpose

Troubleshooting is a systematic isolation and remedy of malfunction and defective components by means of symptoms and tests. Close adherence to the procedures covered herein will materially reduce the time required to locate trouble and restore the equipment to normal operation. The scope and level of Ordnance

maintenance will govern the test and remedies which may be applied.

### 25. Procedure

The troubleshooting procedure outlined in table III is one of determining, upon occurrence of malfunctions noted, the probable cause, and taking the necessary corrective action.

*Table III. Troubleshooting*

Malfunction	Probable cause	Corrective Action
BoreSight worms (elevation and azimuth) loose, causing free movement or lost motion.	Retaining ring loose . . . . .	Tighten retaining ring until proper torque is established on the bore-sight worms (figs. 9 and 11) (pars. 36 and 37).
Boresight worms binding . . . . .	Retaining ring set too tight. . . . .	Loosen retaining ring until proper torque is established on the bore-sight worms (figs. 9 and 11) (pars. 36 and 37).
	Worm threads bured or dirty . . . . .	Remove burs by stoning or clean with crocus cloth (figs. 7 and 10) (par. 43). Check gasket and preformed packing for defects. Replace as necessary (figs. 8 and 10) (pars. 35 and 38).
Mount does not properly accept telescope M 103.	Burs on key in mount . . . . .	Stone burs on key (fig. 10) (par. 43).
	Shield bent (not concentric) . . . . .	Replace shield (fig. 10) (par. 35).
	Burs on thread segments . . . . .	Remove burs by stoning.
	Spring broken . . . . .	Replace spring (fig. 10) (par. 35).
Ring assembly (mounting)	Nylon pins worn and do not grip threads on mount housing properly.	Replace nylon pins in ring assembly (fig. 7) (par. 39).
	Threads stripped on ring assembly.	Replace ring assembly (fig. 7) (par. 39).

# CHAPTER 5

## REPAIR AND OVERHAUL

---

### Section I. GENERAL

#### 26. Scope

This chapter contains specific maintenance instructions for the repair and overhaul of telescope mount M110. When it is found, during inspection, that equipment does not meet the required performance characteristics, overhaul in accordance with the concept of IROAN (Inspect and Repair Only As Necessary). This technique will be used, involving a minimum of disassembly, in order to replace or repair a defective component. There are no repair

parts authorized for field maintenance (3d and 4th echelon).

#### 27. References

Organizational maintenance of telescope mount M110 is covered in TM 9-1015-223-12, which also contains boresighting and installation procedures. General maintenance procedures are furnished in TM 9-254 and personnel should become familiar with its contents before attempting the procedures described in this manual.

### Section II. DISASSEMBLY

#### 28. General

This section describes disassembly of telescope mount M110 completely to its smallest component. If repair or overhaul is confined to one assembly, remove only the components necessary to effect the necessary repair or overhaul.

#### 29. Ring Assembly

Remove ring assembly using pin-type spanner wrench 8213920 (fig. 6). Disassemble ring assembly in legend sequence (fig. 7).

#### 30. Boresight Worms

Remove boresight worms (elevation and azimuth) in legend sequence (fig. 7).

#### 31. Retainer and Gasket

Remove retainer, gasket, and setscrews in legend sequence (fig. 8).

#### 32. Retaining Ring

Remove retaining ring using tubular spanner wrench 5120-345-1417 (fig. 9).

#### 33. Gimbal Tube, Wedge Gears, and Spring Assembly

a. Remove and disassemble components in legend sequence (fig. 10).

Caution: Do not attempt to remove the spring assembly unless it is worn or broken or the boresight mechanism is *defective* and must be replaced. The spring assembly may be broken during removal.

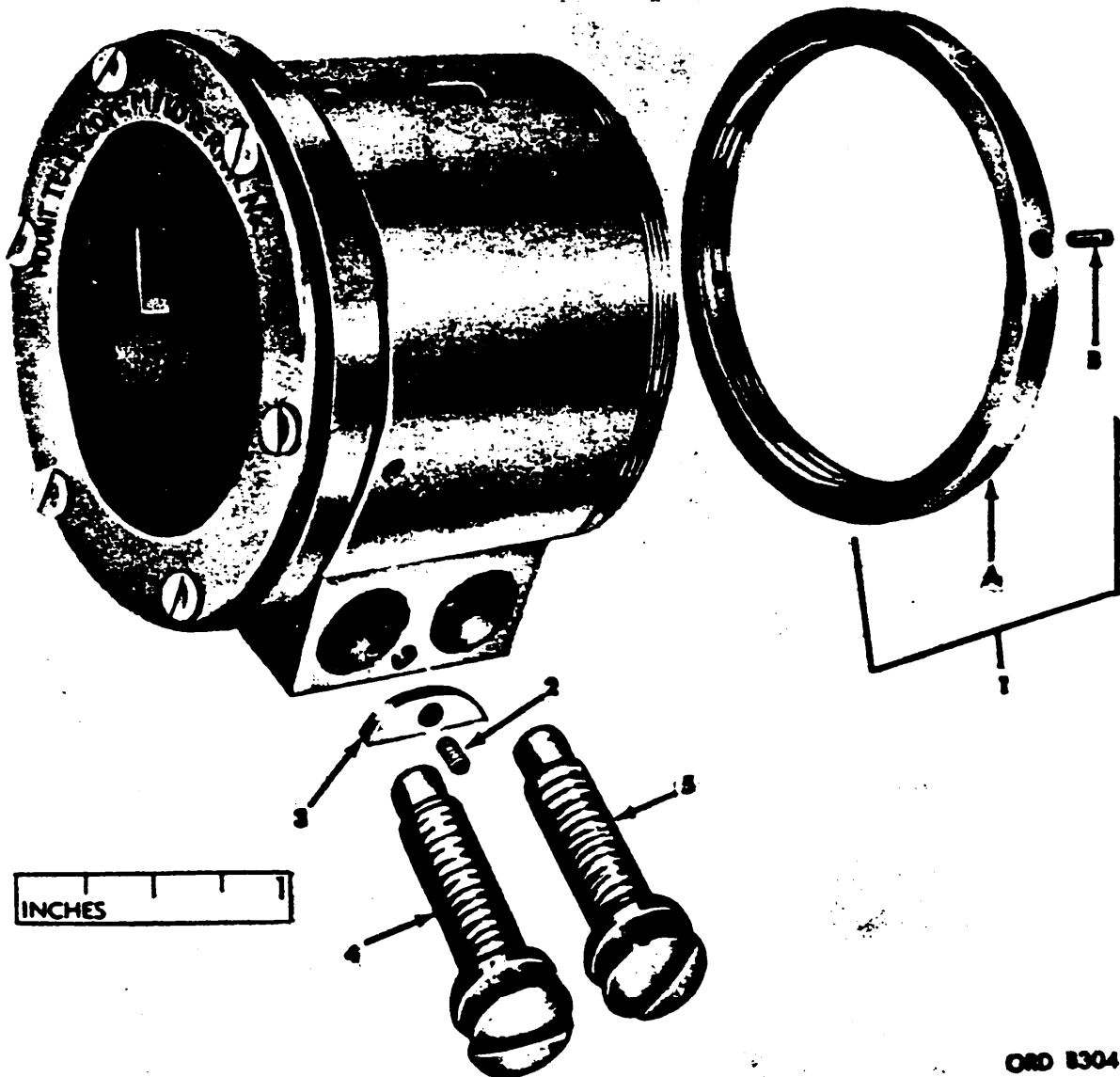

Figure 6. Removal of ring assembly.

b. To remove the spring assembly, insert a blunt tool between the shield and the spring on the side opposite the key. Separate the shield from the spring and release the end of the shield from the slot under the key. Exercise extreme care bending the shield to avoid creasing the metal.

c. Insert a thin-bladed tool between the spring and the gimbal tube, pry the pins of the spring assembly from the holes in the tube, and force the edge of the spring into the tube so that it clears the other edge of the spring. Coil the spring assembly slightly and remove from tube.

- 1—RING ASSY.—8634485
- A—RING—7659772
- B—0.945 x 5/32 PLASTIC NYLON PIN—8634486
- 2—NO. 4—48 x 1/8 CUP POINT SETSCREW—9400803
- 3—HALF ROUND KEY—7659779
- 4—ELEVATION BORESIGHT WORM—7659773
- 5—AZIMUTH BORESIGHT WORM—7659773



ORD 83041

Figure 7. Telescope mount M110 - partial exploded view.



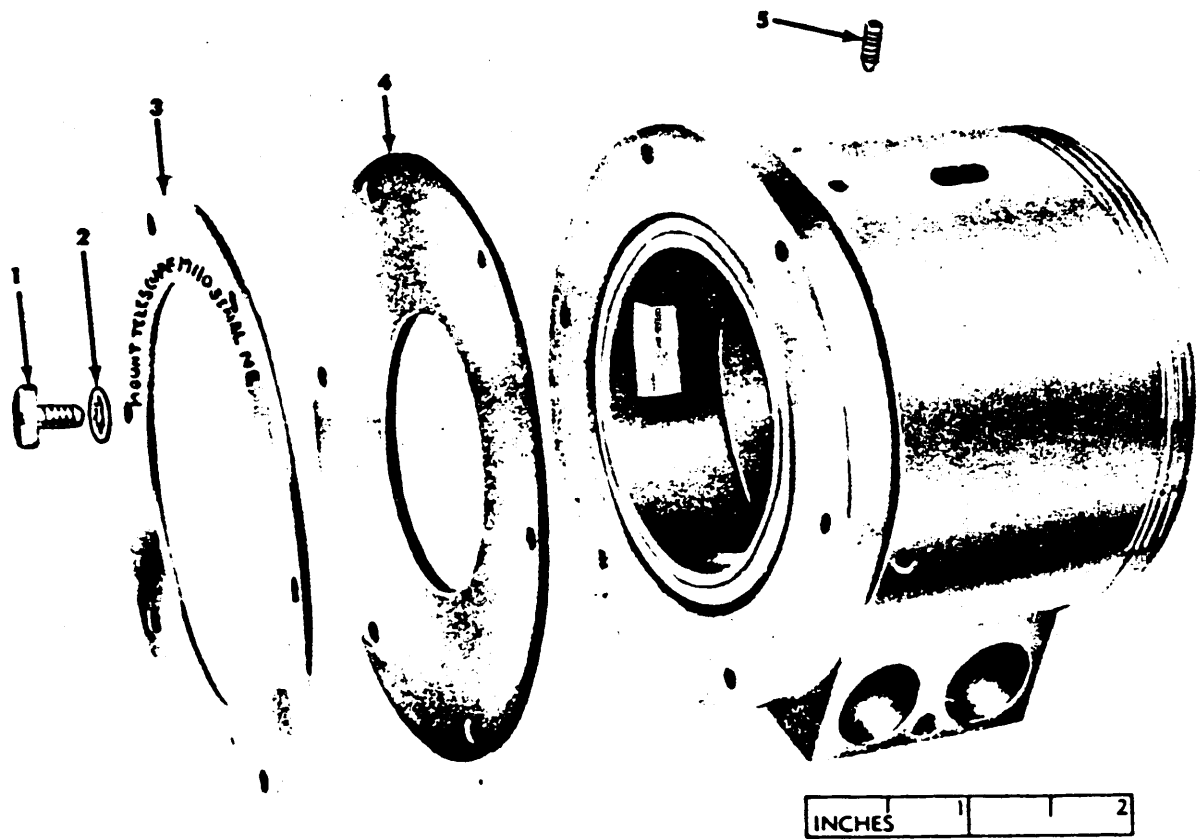

- 1—NO. 2 x 3/16—PAN HEAD SCREW—(6)—MS35234—2
- 2—NO. 2 FLAT INTERNAL TOOTH LOCKWASHER—MS35333—69
- 3—RETAINER—7659774
- 4—GASKET—7659775
- 5—NO. 4 x 1/8—CONE POINT SOCKET SETSCREW—(2)—588631

ORD B3042

Figure 8. Telescope mount M110 - partial exploded view.

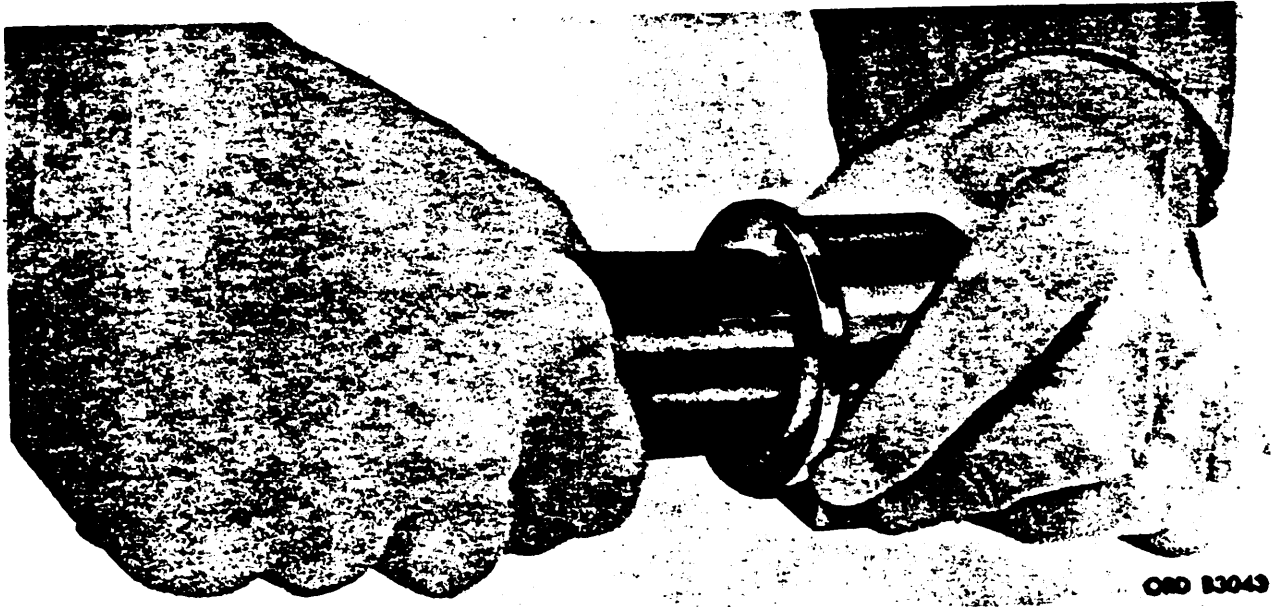

ORD 83043

Figure 9. Removing or installing retaining ring.

- 1—RETAINING RING—7659771
- 2—WEDGE GEAR—7659770
- 3—SPRING ASSY—7659768
  - A—CK—HEAD PLUG—(2)—225082
  - B—KEY—7659777
  - C—SHIELD—7659778
  - D—ACCORDIAN TYPE SPRING—7659769
  - E—1/16 x 3/32 STRAIGHT HEADLESS PIN—(2)—805549
- 4—1/8 x 7/32 STRAIGHT HEADLESS PIN—544114
- 5—GIMBAL TUBE—7659767
- 6—WEDGE GEAR—7659770
- 7—SHOE—(4)—7659776
- 8—PREFORMED PACKING—7687317
- 9—HOUSING—7659766

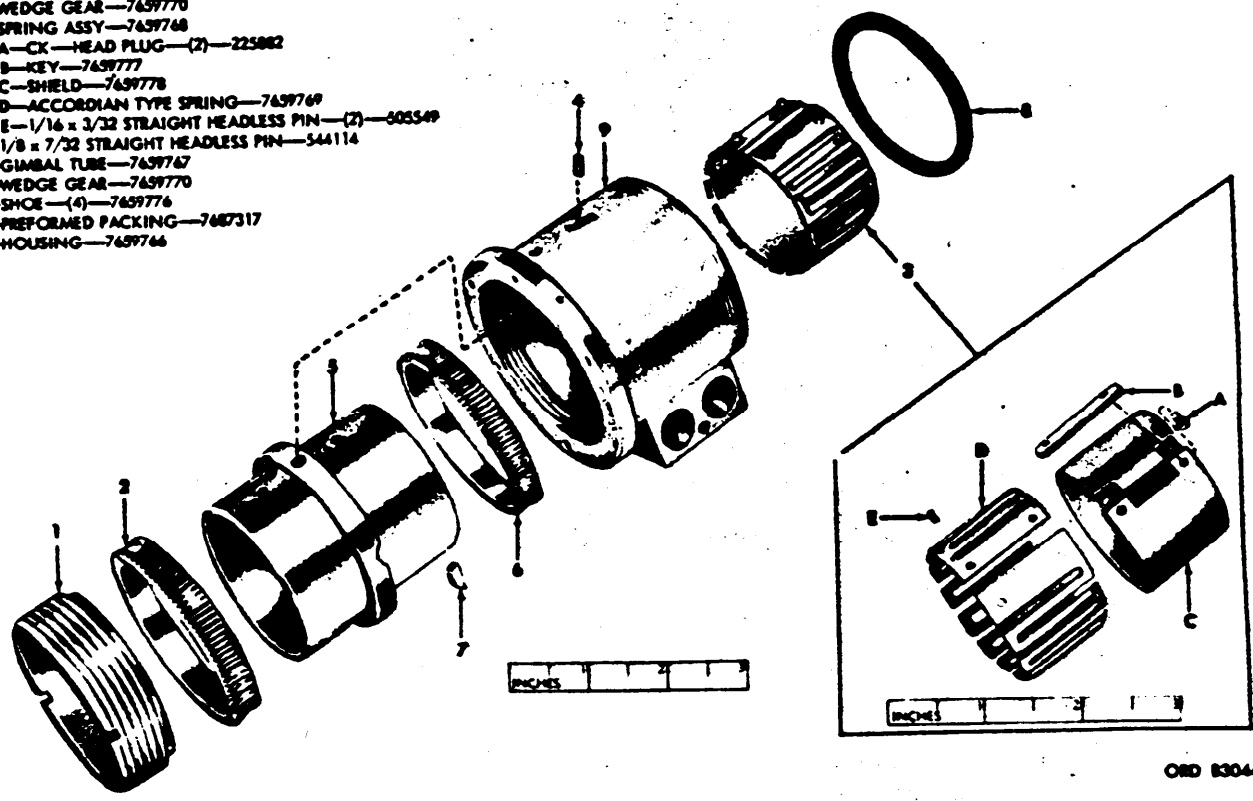

ORD 83044

Figure 10. Telescope mount M110 - partial exploded view.

## Section III. ASSEMBLY

### 34. General

a. *Painting.* Paint all exposed surfaces so that the equipment will have the appearance of a new item. Refer to TM 9-2851 for detailed instruction on painting. Bearing surfaces, mating surfaces, screw threads and all other critical surfaces must not show traces of paint or primer. Painting of the parts should be done at the most practicable stage of assembly.

b. *Lubrication.* For parts requiring lubrication, use aircraft and instrument grease MIL-G3278

### 35. Gimbal Tube, Wedge Gears, and Spring Assembly

Assemble and install component in reverse legend sequence (fig. 10). Placing wedge gears on the tube with the inclined faces of the gears against the shoes. Apply grease to wedge gears and shoes. Install retaining ring using tubular spanner wrench 5120-345-1417 (fig. 9).

### 36. Boresight Worms

Install boresight worms (elevation and azimuth) in reverse legend sequence (fig. 7) applying grease to worms.

*Note.* Before complete assembly of the telescope mount, the test and adjustment of the torque requirement, should be accomplished. The torque required for clockwise and counterclockwise rotation of the azimuth and elevation worms shall be not less than 8-inch-ounces.

### 37. Setting Torque

Using torque screwdriver 5120-568-4749 (fig. 11), check torque, tightening or loosening retaining ring with tubular spanner wrench until proper amount is established. Tighten setscrews (fig. 8), and seal using sealing compound MIL-S-11031.

### 38. Retainer and Gasket

Install retainer and gasket in reverse legend sequence (fig. 8).

### 39. Ring Assembly

Assemble pins to ring (fig. 7) and install.

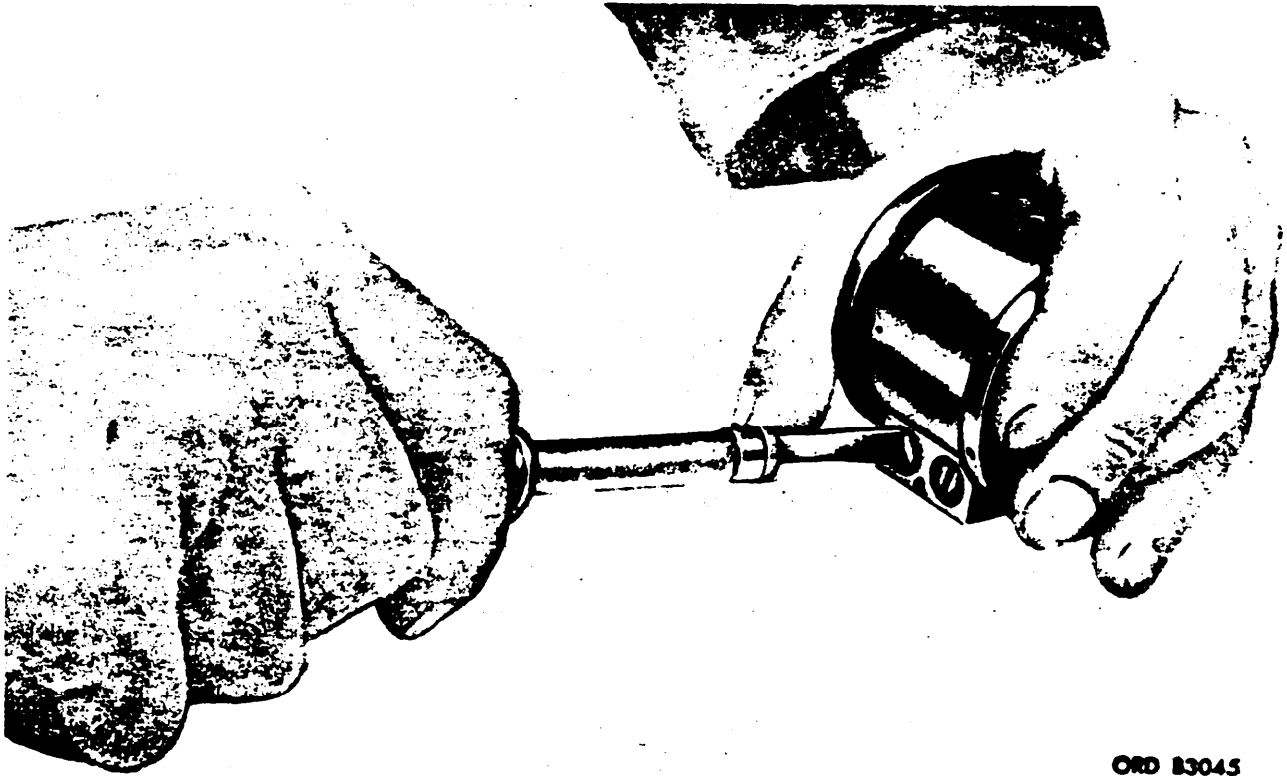

ORD 83045

Figure 11. Torque test on boresight worms.

#### Section IV. TEST AND ADJUSTMENT

##### 40. General

The test and adjustment that follow are performed after the telescope mount has been completely assembled. The tools and equipment necessary to perform these tests and adjustments are listed in tables I and II.

##### 41. Vibration Test

Prior to other test and adjustments, the telescope mount must be vibrated for 1-1/2 minutes at a constant frequency of 30 cycles per second with an amplitude of 1/16 inch to check for loose components (1/8-inch maximum excursion) on the universal vibration tester 7560085 (fig. 2).

a. Test adapter 8213875 and necessary clamps (fig. 12) should be used to secure the telescope mount to the vibration tester.

b. After proper settings of the vibration tester, press the start button, timing the length of vibration 1-1/2 minutes.

c. After being subjected to the vibration test, the telescope mount should show no evidence of loose components. If loose components are present they must be corrected and the operation repeated.

##### 42. Setup of Test Equipment

Before further testing or adjusting of the telescope mount M110, set up the test equipment as in a through o below.

a. Place the telescope test fixture 7573980 (fig. 2) on a flat, stable, leveled surface.

b. Install "J" Support 7680666 in the movable support of the fixture.

c. Clamp a collimating telescope 5549108 in a precision "V" block on a leveled surface plate (fig. 13). Loosen clamp and rotate collimating telescope in "V" block until one of the reticle lines coincides with a true vertical line as established by a plumb line. Secure telescope

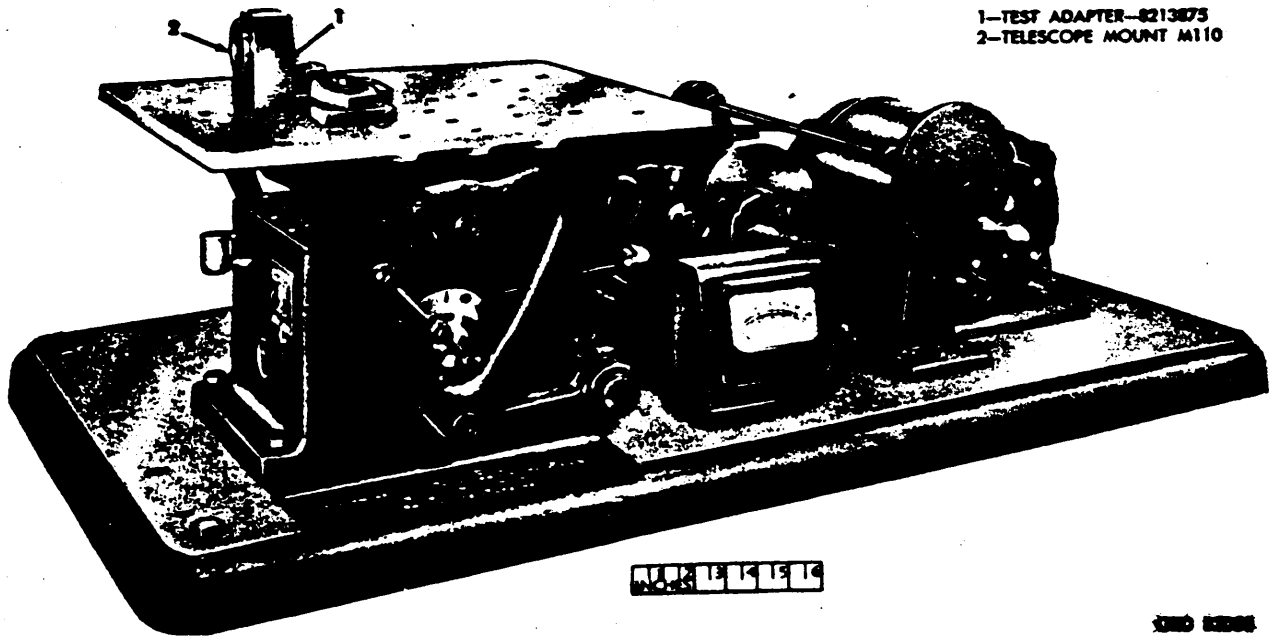

Figure 12. Vibration test.

with clamp and recheck setting.

d. Place the "V" block on the "J" support. Adjust the support placing collimating telescope approximately at the same height as the projector collimator. Position the "V" block on the support until the telescope's line of sight is directed into the projector collimator.

e. Loosen the four socket-head cap-screws on the clamps of the projector collimator support assembly. Rotate the projector collimator until the vertical reticle line is in coincidence with the vertical reticle line of the collimating telescope. Tighten the screws securing projector collimator and recheck setting. Remove "V" block from support.

f. Rotate the adjustable objective scale (fig. 2) until the 100-yard range mark is indexed.

g. Rotate the lamp housing on the projector collimator tube until the 90-degree opening is approximately horizontal. Remove the diffusion screen and insert the extension cord lamp socket, plugging the other end to a 110-volt outlet.

n. Install bracket assembly 7680659 on the "J" support and insert reflecting mirror 5181003 into the bracket assembly.

The reflecting surface of the mirror must face the projector collimator (fig. 2).

i. Sight through the opening in the lamp housing. The reflected image and real image of the projector collimator reticle should be superimposed. Adjusting screws with locks are provided on the collimator support for superimposing. Remove the mirror and bracket from the "J" support. Replace diffusion screen and remove lamp from 90-degree opening, and install in the end of lamp housing.

j. Place alignment test adapter in a precision "V" block and clamp lightly. Clamp "V" block to an adjustable angle plate, that has been secured to a leveled and crossleveled surface plate. Insert setup block in keyway of alignment test adapter and with a dial indicator attached to a height gage, indicate entire surface of setup block. Rotate alignment test adapter and adjust "V" block until a zero reading over the entire surface is attained. Secure "V" block and adapter and recheck (fig. 14).

k. Loosen locking nut on adjustable angle plate, and with a vernier bevel protractor, set angle plate to 26 degrees plus or minus

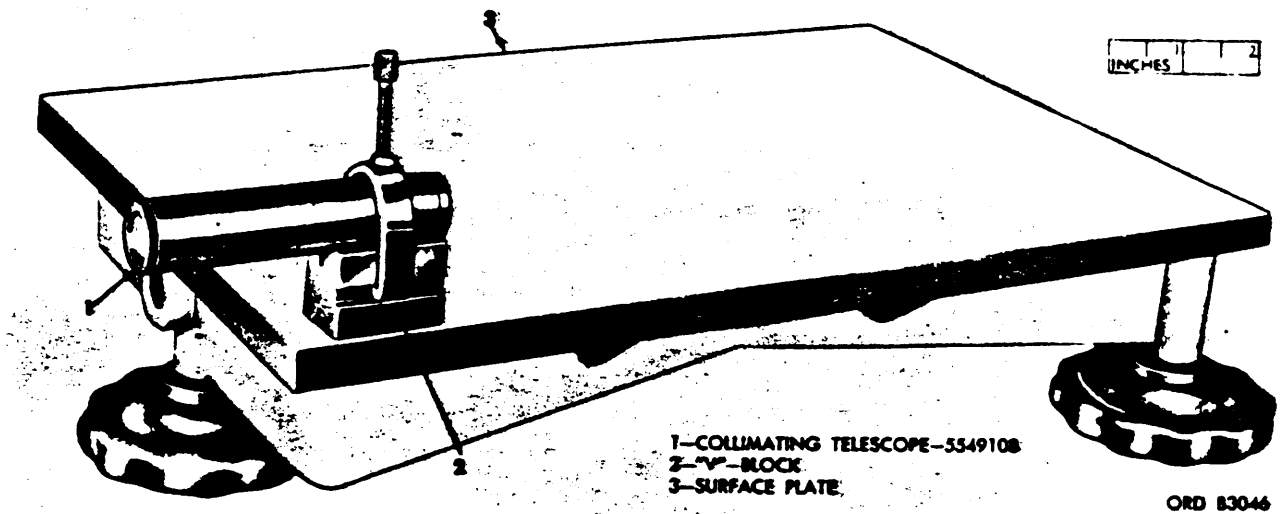

Figure 13. Plumbing reticle of collimating telescope.

0 minutes, to the left of the vertical (fig. 15).

1. Insert collimating telescope 5549108 (fig. 5) into alinement test adapter and rotate until one of the reticle lines coincides with a true vertical line as established by a plumb line. Tighten setscrew in adapter securing collimating telescope and recheck reticle plumb (fig. 15).

m. Install test adapter 8213875 on "J" support 7680666 (fig. 16).

n. **Install telescope mount M110** to the test adapter using spanner wrench 8213920.

o. Install alinement test adapter with collimating telescope into telescope mount M110 (fig. 16) raise or lower "J" support to put reticle of collimating telescope in alinement with the projector collimator. Slide the movable support assembly until a sharp image of the projector collimator reticle is viewed through the collimating telescope and lock support in this position.

#### 43. Test and Adjustments

With the flat base of the mount set at angle of 45 degrees as established by the test adapter, perform the following functions.

a. *Orientation.* Viewing the target reticle of the projector collimator through the collimating telescope, turn the elevation

and azimuth boresight worms until collimating telescope reticle is superimposed on the target.

b. *Azimuth movement.*

(1) *Test.* Rotation of the azimuth boresight worm (fig. 7) shall move the line of sight of the collimating telescope in a horizontal plane through an excursion of a minimum of 17 mils to the right and 17 mils to the left from the midpoint of travel, as measured on the projector collimator reticle.

(2) *Adjustment.* Disassemble, and check for shoes out of position or defective, and for burs or dirt on the wedge gears or boresight screws. Remove burs or dirt; then clean, lubricate, assemble, and recheck.

c. *Elevation movement.*

(1) *Test.* Rotation of the elevation boresight worm (fig. 7) shall move the line of sight of the collimating telescope in a vertical plane through an excursion of a minimum of 17 mils above and 17 mils below from the midpoint of travel, as measured on the projector collimator reticle.

(2) *Adjustment.* The same functions will be performed for adjustment of elevation movement as b(2) above.

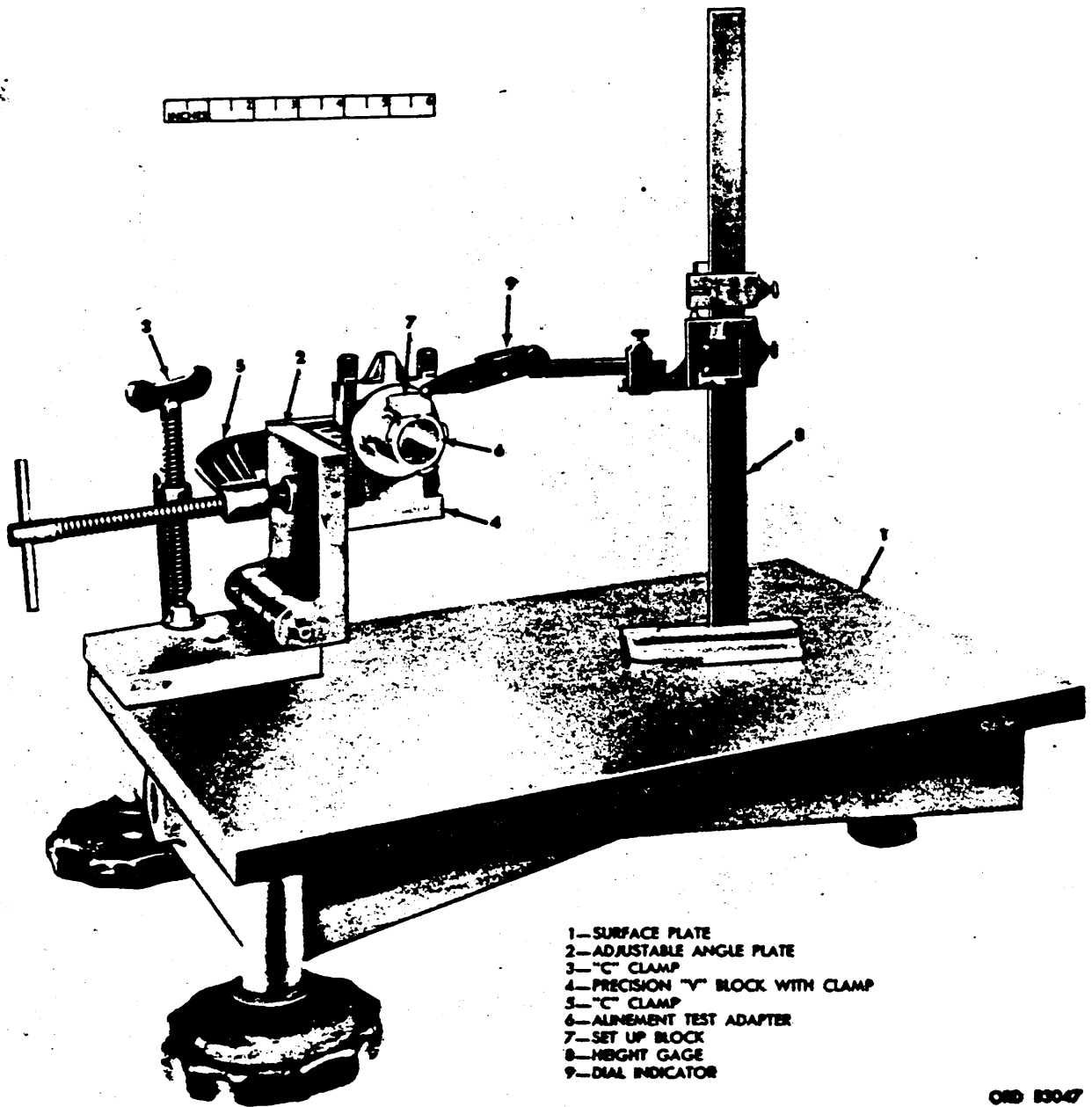
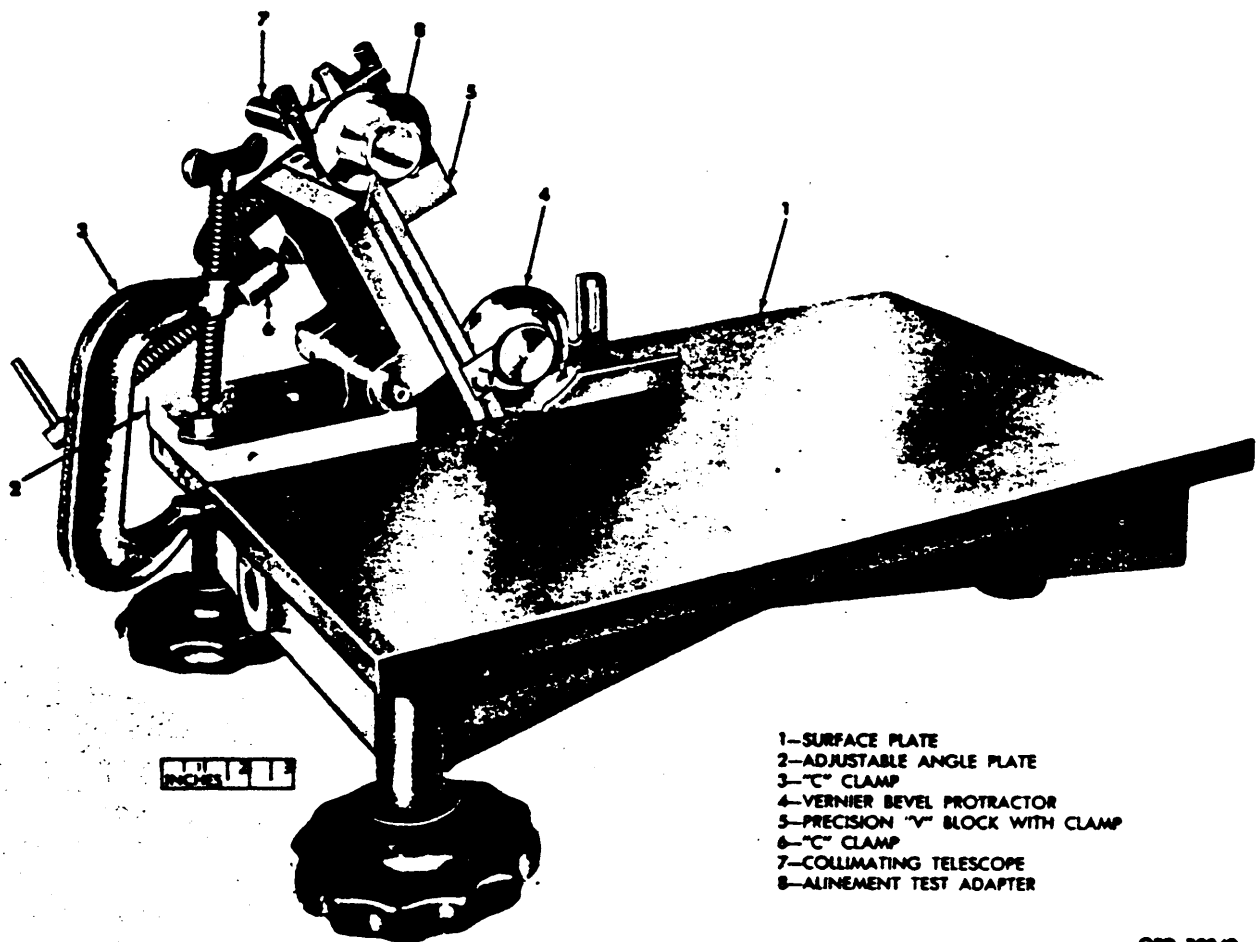

Figure 14. Setting up alinement adapter



ORD 83048

Figure 15. Alining collimating telescope to adapter.



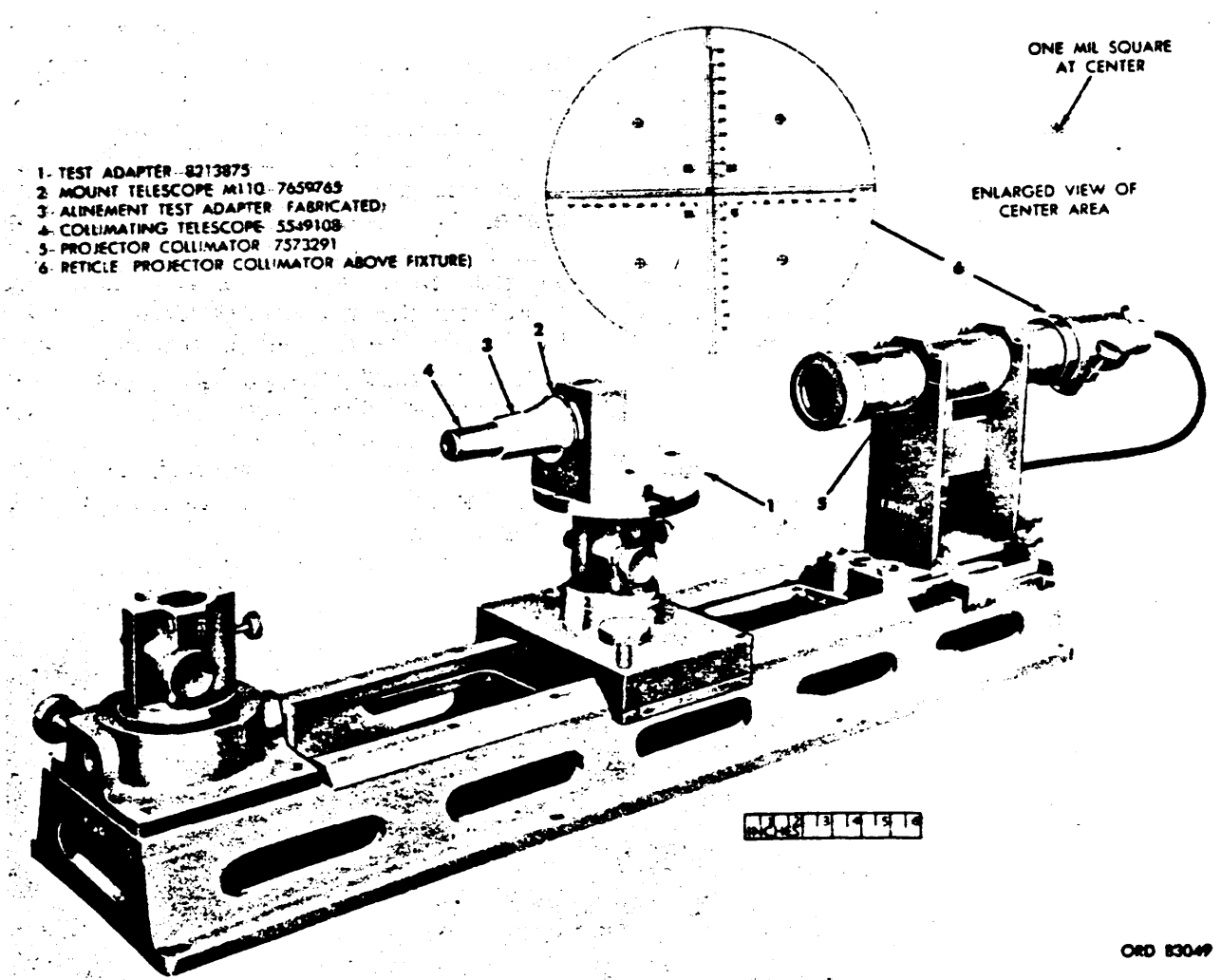

Figure 16. Testing boresight worms.

## CHAPTER 6

### FINAL INSPECTION

---

#### 44. General

Final inspection is performed after repair or overhaul has been completed to insure that the materiel is serviceable according to the established serviceability standards. Any item containing defects disclosed by the final inspection will be returned to the shop for repair or adjustment.

#### 45. Visual Inspection

Visually inspect telescope mount M110 in accordance with paragraph 19.

#### 46. Final Inspection for Acceptance

*a. Vibration.* The telescope mount M110 shall be vibrated as described in paragraph 41. Subsequent to vibration tele-

scope mount shall show no evidence of loose or damaged parts.

*b. Set-up procedure.* Install telescope mount as in paragraph 42, with the flat base positioned at 45 degrees plus or minus 10 minutes.

*c. Azimuth movement.* A minimum of 17 mils to the right and 17 mils to the left in a horizontal plane from the midpoint of travel, as described in paragraph 43.

*d. Elevation movement.* A minimum of 17 roils in elevation and 17 mils depression from the midpoint of travel in a vertical plane, as described in paragraph 43.

*e. Boresight worms.* The requirements of 8 inch-ounces of torque, will be required as in paragraphs 36 and 37.

*f. Sealing.* Sealing will be in accordance with the latest Ordnance drawings for the telescope mount M110.

# CHAPTER 7

## PROCESSING AND PACKAGING

---

### 47. General

Refer to TM 9-200 (boxed materiel) and

TB 9-299/1 (unboxed materiel) for processing and packaging instructions at levels A, B, and C.

# APPENDIX

## REFERENCES

---

### 1. Publication Indexes

The following indexes should be consulted frequently for the latest changes or revisions of references given in this appendix and for new publications relating to materiel covered in this manual.

Index of Army Motion Pictures, Film Strips, Slides, and Phono-Recordings.	DA Pam 108-1
Military Publications:	
Index of Administrative Publications - - - - -	DA Pam 310-1
Index of Blank Forms - - - - -	DA Pam 310-2
Index of Graphic Training Aids and Devices - - - - -	DA Pam 310-5
Index of Supply Manuals; Ordnance - - - - -	DA Pam 310-29
Index of Technical Manuals, Technical Bulletins, Supply Bulletins, Lubrication Orders, and Modification Work Orders.	DA Pam 310-4
Index of Training Publications- - - - -	DA Pam 310-3

### 2 Supply Manuals

The following manuals of the Department of Army supply manuals pertain to this materiel.

<i>a. Destruction to Prevent Enemy Use.</i>	
Ammunition: Explosives, Bulk Propellants, Explosive Devices.	SM 9-5-1375
<i>b. General.</i>	
Introduction - - - - -	<b>ORD 1</b>
<i>c. Repair and Overhaul.</i>	
Brushes, Paints, Sealers, and Adhesives - - - - -	SM 9-1-8000
Fuels, Lubricants, Oils, and Waxes - - - - -	SM 10-1-9100
Hardware and Abrasives - - - - -	SM 9-1-53(*)
Maintenance and Repair Shop Equipment - - - - -	SM 9-1-4900
Special Tool Sets for Sighting and Fire Control Materiel Used With Small Arms, Automatic Guns, Mortars, and Field Artillery (SNL Group F),	ORD (*) SNL J-32
Tool Kit, Fire Control Repairman (5180-357-7735) - - - - -	SM 9-4-5180-A61
Tool Kit, Instrument Repairman's (5180-357-7743) - - - - -	SM 9-4-5180-A62

### 3. Forms

DA Form 9-1, Materiel Inspection Tag
DA Form 9-12, Inspection of Ordnance Equipment
DA Form 9-79, Part Requisition
DA Form 9-80, Job Order File
DA Form 9-81, Exchange Part or Unit Identification Tag
DA Form 421, Stock Record Card

---

(\*)See DA Pam 310-29-810-29, Index of Supply Manuals - Ordnance Corps, for published manuals of the Ordnance section of the Department of the Army.

DA Form 468, Unsatisfactory Equipment Report  
 DA Form 811, Work Request and Job Order  
 DA Form 828, Job Time Ticket- Individual  
 DA Form 829, Rejection Memorandum  
 DA Form 1546, Request for Issue or Turn-In  
 DA Form 1739, Command Maintenance Inspection - Fire Control Equipment  
 Inspection Report - Ordnance Equipment  
 DA Form 2028, Recommended Changes to DA Technical Manual,  
 Parts List or Supply Manual 7, 8, or 9  
 DD Form 6, Report of Damaged or Improper Shipment  
 DD Form 250, Materiel Inspection and Receiving Report

**4. Other Publications**

<i>a. Camouflage.</i>	FM 5-20
Camouflage, Basic Principles and Field Camouflage - - - -	
<i>b. Decontamination.</i>	TM 3-220
Decontamination - - - - -	FM 21-40
Small Unit Procedures in Atomic, Biological, and Chemical Warfare.	
<i>c. Destruction to Prevent Enemy Use.</i>	FM 5-25
Explosives and Demolitions- - - - -	FM 9-5
Ordnance Ammunition Service- - - - -	AR 385-63
Safety: Regulations for Firing Ammunition for Training, Target Practice, and Combat.	AFR 50-13
<i>d. General.</i>	
Logistics (General):	AR 700-1300-8
Malfunctions Involving Ammunition and Explosives - - - -	AR 700-38
Unsatisfactory Equipment Report - - - - -	FM 21-30
Military Symbols	AFM 55-3
 Military Terms, Abbreviations, and Symbols:	
Authorized Abbreviations and Brevity Codes - - - - -	AR 320-50
Dictionary of United States Army Terms - - - - -	AR 320-5
Military Training- - - - -	FM 21-5
Principles of Fire Control Materiel - - - - -	TM 9-3305-2
Safety: Accident Reporting and Records - - - - -	AR 385-40
Shop Mathematics- - - - -	TM 9-2820
Techniques of Military Instructions - - - - -	FM 21-6
<i>e. Maintenance.</i>	
Field and Depot Maintenance Repair Parts and Special Tool Lists for Telescope Mount M110.	TM 9-1240-297-35P
Field Control Materiel; Lubrication - - - - -	TB 9-2835-1
General Maintenance Procedures for Fire Control Materiel-	TM 9-254
Inspection of Ordnance Materiel in Hands of Troops - - - - -	TM 9-1100
Instruction Guide: Elementary Optics and Application to Fire Control Instruments.	TM 9-2601
Lubrications - - - - -	TM 9-2835
Operation and Maintenance of Ordnance Materiel in Extreme Cold Weather, 0° to -65° F.	TM 9-207
Maintenance and Care of Hand Tools - - - - -	TM 9-867
Maintenance of Supplies and Equipment:	AR 750-8
Command Maintenance Inspection.	

Maintenance of Supplies and Equipment: Spot Check Inspection and Reports; Ordnance Corps Materiel.	AR 750-925
Materials Used for Cleaning, Preserving, Abrading, and Cementing Ordnance Materiel; and Related Materials Including Chemicals.	TM 9-247
Northern Operations - - - - -	TM 31-71
Ordnance Direct Support Service - - - - -	FM 9-3
Ordnance General and Depot Support Service - - - - -	FM 9-4
Painting Instructions for Field Use - - - - -	TM 9-2851
<i>f. Operation.</i>	
Artillery Materiel and Associated Equipment - - - - -	TM 9-2300
Auxiliary Sighting and Fire Control Equipment - - - - -	TM 9-575
Operator and Organizational Maintenance for 90-mm Rifle M67.	TM 9-1015-223-12
<i>g. Shipment and Storage.</i>	
General Packaging Instructions for Ordnance General Supplies.	TM 9-200
Issue of Supplies and Equipment: Preparation, Processing, and Documentation for Requisitioning, Shipping and Receiving.	AR 725-5
Logistics (General): Report of Damaged or Improper Shipment.	AR 700-58
Marking and Packing of Supplies and Equipment: Marketing of Supplies for Shipment.	AR 746-80
Preservation, Methods of - - - - -	MIL-P-116
Processing of Unboxed Self-Propelled and Towed Class II Ordnance General Supplies and Related Materiel for Shipment and Storage.	TB 9-299/1
Protection of Ordnance General Supplies in Open Storage.	TB ORD 379
Standards for Oversea Shipment and Domestic Issue of Ordnance Materiel Other than Ammunition and Army Aircraft.	TB ORD 385
Storage of Shipment of Supplies and Equipment: Preservation, Packaging and Packing.	AR 740-15
Storage of Supplies and Equipment: Storage and Materials Handling.	TM 743-200-1

## INDEX

	Paragraph	Page		Paragraph	Page
Accidents, field report of -----	3c	3	Packaging and processing -----	47	25
Assembly -----	34-39	17	Painting -----	34a	17
Authorized forms -----	3a	2	Records (See Forms, records, and reports)		
Azimuth movement -----	43b	20	Repair and overhaul:		
Classification of materiel:			Scope -----	26	13
Serviceable -----	16a	9	References -----	27	13
Unserviceable -----	16b	10	Reports (See Forms, records and reports)		
Data -----	6	3	Scope of Manual -----	1	2
Description -----	4,5	3	Tables:		
Disassembly -----	28-33	13	Fabricated tools (table II) -----		5
Elevation movement -----	43c	20	Special tools and equipment for depot maintenance (table I) -----		4
Equipment (See Tools and equipment)			Troubleshooting (table III) -----		12
Forms, records, and reports -----	3,18	2,10	Test and adjustments:		
Inspection:			Azimuth movement -----	43b	20
Categories -----	15	9	Elevation movement -----	43c	20
Final:			General -----	40	18
Acceptance -----	46	24	Orientation -----	43a	20
General -----	44	24	Set-up of test equipment -----	42	18
Visual -----	45	24	Vibration test -----	41	18
In the hands of troops -----	17-19	10	Tools and equipment:		
Ordnance shop:			Common -----	8	4
General -----	20	10	Fabricated -----	12	5
Inspection -----	21	10	General -----	7	4
Pre-embarkation:			Special -----	9	4
General -----	22	11	Telescope test fixture -----	10	4
Inspection -----	23	11	Universal vibration tester -----	11	5
Modification work orders -----	23b	11	Troubleshooting:		
Purpose -----	14	9	Procedure -----	25	12
Scope -----	13	9	Purpose -----	24	12
Lubrication -----	34	17	Unsatisfactory equipment or materials -----	3d	3
Maintenance:					
Allocation and parts -----	2	2			
Orientation -----	43a	20			

By Order of Secretary of the Army:

G. H. DECKER,  
General, United States Army,  
Chief of Staff

Official:

R. V. LEE,  
Major General, United States Army  
The Adjutant General.

Distribution:

*Active Army:*

DCSLOG (1)	Units org under fol TOE:
Tech Stf, DA (1) except	(2 copies each)
CofOrd (9)	9-7
CofT (none)	9-9
Ord Bd (2)	9-12
USCONARC (2)	9-25
ARADCOM (2)	9-26
ARADCOM Rgn (2)	9-27
MDW (1)	9-57
Armies (3)	9-65
Corps (2)	9-66
Instls (2)	9-67
Ord Dep (2)	9-76
Arsenals (2) except	9-167
Raritan Arsenal (15)	9-367
USA Corps (2)	9-500 (BA, BB, DA, DB)

**NC: None.**

**USAR: Same as Active Army except allowance is one copy to each unit.**

**For explanation of abbreviations used, see AR 320-50.**





